

MATHIAS
VESTERGAARD™
CORP.

Annual Report 2012

Where We Left

The year 2011 was the year a big dream came true. A dream about leaving Denmark behind and moving to New York with intention to stay. It was a year of connecting with a deep sense of purpose. A time of dramatic changes that allowed me to begin really growing into myself. It was also the year where I was introduced to Graphic Facilitation as both a tool and a potential career path. And it was a year of many different projects including both websites, books and photography. If you want to read or re-read the 2011 Annual Report it can be downloaded from www.mathiasvestergaard.com/2011



I HAVE TIME TO READ
REALLY GREAT BOOKS

Contents

_2011 recap.....	2
_Before we get started.....	3
_Letter from the board of directors.....	4
Finding home	
_My new family.....	9
_Flying.....	10
_Build a Gulfstream in LEGO.....	11
_Airplane poems.....	12
Take-off	
_Over the edge.....	15
_Daring to ask for help.....	16
_New business model.....	17
_Big dream came true.....	18
_Even bigger dream.....	19
_Looking into the future.....	20
_Focus.....	22
Intentional	
_Making and breaking habits.....	30
_Guidelines for life.....	32
_Investing meaning into objects.....	34
_Role models.....	35
_Stress and fears.....	36
_Baking bread.....	38
_Integrating goals.....	39
_Books I have enjoyed.....	40
Summing up and looking ahead	
_My biggest successes.....	45
_Looking ahead.....	46

I HAVE PROFESSIONAL
WORK THAT IS MEANINGFUL
AND AT THE SAME TIME,
I CAN HAVE BAKING AS
A PASSIONATE HOBBY.



DESPITE NOT BEING
BUSY WITH CLIENT
WORK I CAN STILL
EARN A LIVING.



Before we get started

November 9th: Sometimes I like to stop and notice the wonderful things around me.

MY DIOR SUIT AND
DC SNEAKERS HAVE
BEEN REPAIRED AND
ARE READY TO USE



I CAN AFFORD TO
DRINK INCREDIBLE
COFFEE WHEN I
FEEL LIKE IT.

a few
reasons why
LIFE is
amazing
right now



BOTH PERVILLE AND
I NOW HAVE A FORM
OF HEALTH INSURANCE

I HAVE NEW CLIMBING
SHOES THAT ARE
REALLY COOL.



I'LL BE GOING TO
SAN FRANCISCO
NEXT WEEK.

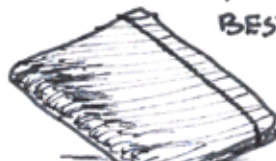

I GET TO USE THE
BEST NOTEBOOKS.
(AFTER A SHORT
DETOUR)

Settle in and take off

The year 2011 marked the beginning of a journey. Both outward in terms of moving from Denmark to New York, but also an inward discovery of meaning and purpose, through meditation. In 2012 this journey has continued. In fact, it now appears that even the major shifts and changes of 2011 were just the preparation. Like an airplane getting ready to fly. Loading the passengers. Loading cargo. Checking all the lights. Testing the engines. Being pushed back from the gate and slowly taxiing towards the runway. It can be a bumpy ride and if you have never flown before, you have no idea what to expect. You try to prepare but you don't know what you're preparing for. The crew is giving instructions. Put the life vest over your head. Blow into the tube. Fasten your seatbelt. It was at this moment my 2012 began. Suddenly the engines roared, I was thrown back into my seat and held on the best I could as the plane launched forward on the runway until the speed of the air around the wings was fast enough to lift the aircraft from the ground. Up in the air. Both literally and metaphorically. 2012 has been a year of immense growth on three levels: socially, I've found my new family of likeminded peers, professionally, my business has really taken off in a very positive way and personally, I have grown to be a fuller version of my true authentic self. Also it was the year where these three things really came together and formed a meaningful whole. My social life launched my business. My business allowed me to explore personal growth. My personal growth fueled back in to my business and my business became an integral part of my social life. In this annual I have ordered my experiences into three main chapters that serve as the main stories of my life

this year: finding home, take-off and intention. In the end I will sum up some key findings, successes and look ahead into 2013. Compared to last year, this annual report is less textually heavy. Instead it is based on fragments and drawings from my notebooks throughout the year, with various amounts of explanation of context. I hope you will enjoy and come along for the ride.



Mathias Vestergaard
Creative Misfit™



WHAT WE FOCUS
ON BECOMES OUR
REALITY





Finding home

—
I knew that moving to New York City felt like moving home, however, it was only in 2012 that I fully understood why and how. I found my new family of peers and I began to feel how home is not so much a place as it is a feeling.

My new family



On January 19th I stepped onto flight CO64 from Newark Airport to Lisbon in order to attend the very first Sandbox Global Summit. I had joined the Sandbox community just weeks before and was incredibly excited to go, however, I would never ever have imagined how much this 72 hour

conference in the capital of Portugal would influence my life in the rest of 2012. When I was there I simply felt I had come home. I felt I was surrounded by likeminded people. People to whom I rarely had to explain everything in words. People who saw me. Understood me.

Global home

In addition to finding my new family in the Sandbox community, I am also becoming increasingly aware that my home is not so much a specific place. The reason why New York is home not just because it's a great and exciting big city, but because it is a global hub that makes me feel connected to Sandboxers and other friends around the globe. When I left Lisbon on January 23rd I knew that I would not be going back to a place that would decrease my chances of seeing all these amazing people again. I was going back to New York where some of them already lived and many of them would surely pass through.

Even before going to Lisbon I anticipated that 2012 would be a year that included a bunch of travel. On Jan-

uary 5th I made the map below trying to imagine where this year would take me and who I already knew in each city. Apart from Memphis and Seoul, I ended up going to all the other cities on the map. Lisbon and LA in January, DC in May, London in June, Copenhagen in August, Boston in September, and San Francisco in November, bringing my total mileage up to roughly 32,000 miles in 12 months.

I still very much enjoy flying. Not that it can't be uncomfortable or frustrating and all that. But there is an essential feeling of ultimate freedom when my body is lifted up in the air. The following pages are dedicated to airplanes and air travel in different ways.

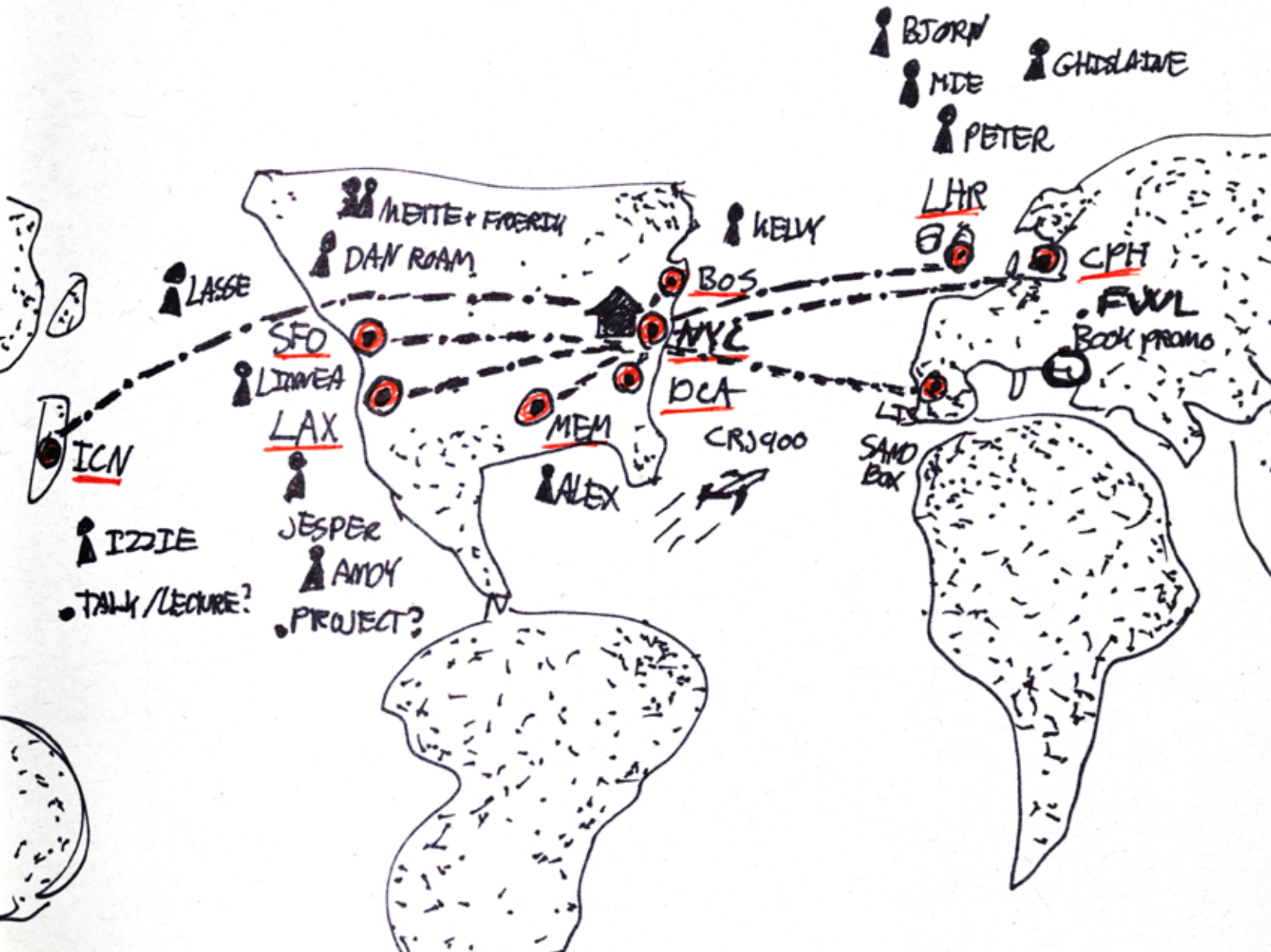

How to build a 1:24 model of a Gulfstream in LEGO

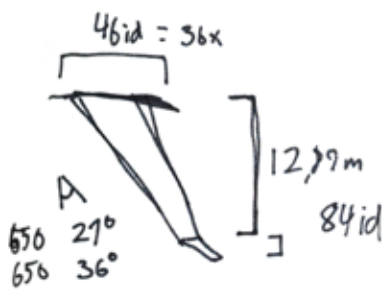
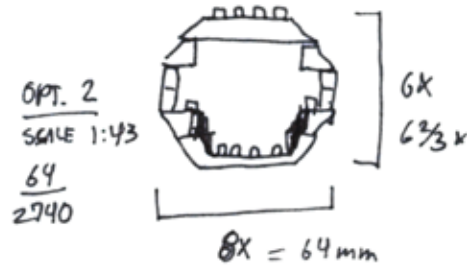
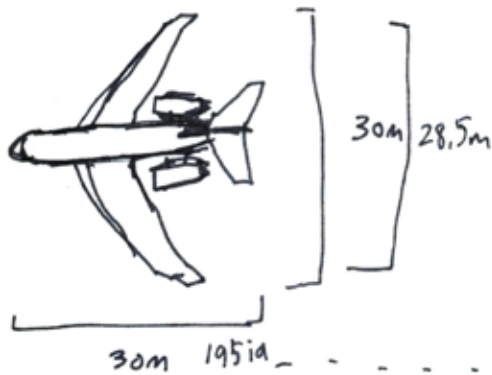
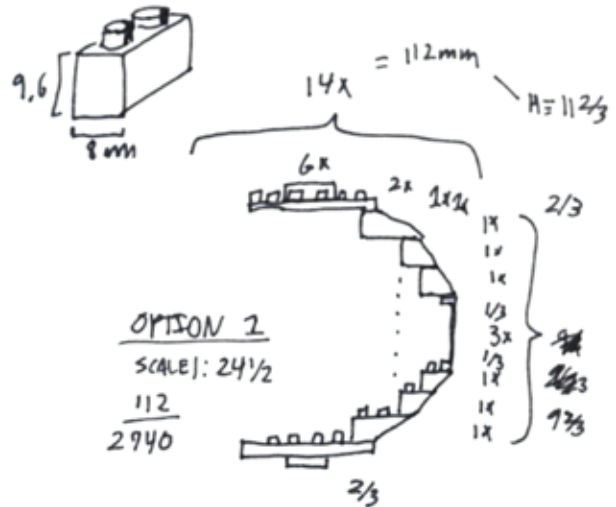
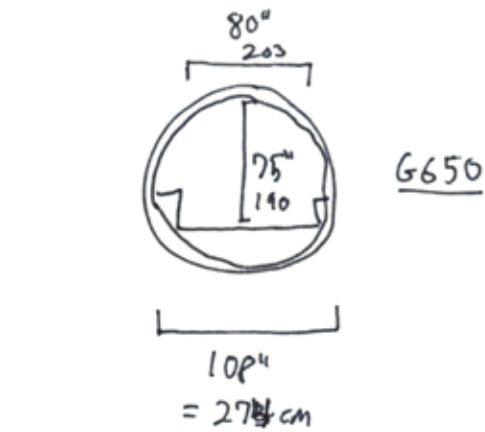

id model
SCALE
156:195

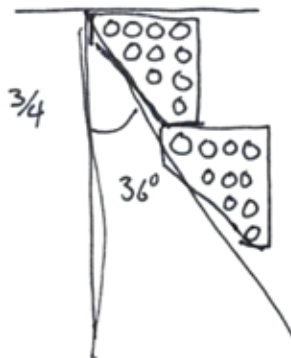
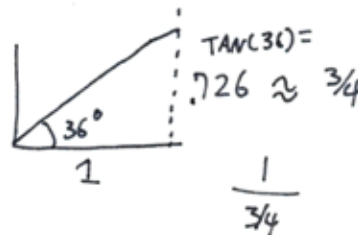

Gulfstream

Home in the sky

When I'm on an airplane, everything is quiet in a certain way. There's the steady humming sound of the wind (and sometimes the engines if I have a seat in the back) and there is a calm atmosphere. Nobody is talking on the phone. Rationally it is completely stupid and quite unnatural to be suspended in mid air, 30,000 feet up, and moving 580 mph. But to me it feels great. It's like a sense

of home in the sky. Yes, that's absurd. But nonetheless the feeling is very real to me. This year I wrote two poems inspired in different ways by airplanes. One is an ode to a particular plane that I very much enjoy. The other just takes place on a private jet in an imagined future on July 8th in the year 2014. Thus the content is an imagined future self, a lyrical "I" and should not be equated with me.

ODE TO CRJ

THE PATIENT AIRPLANES
SITTING IN LINE AT LGA
WAITING FOR THEIR TURNS
TO PRACTICE THEIR OFTEN
UNAPPRECIATED MAGIC:
LIFTING THEMSELVES
AND EVERYONE AND EVERYTHING
ONBOARD INTO THE AIR
A SMALL REGIONAL JET
TOUCHES DOWN ON THE RUNWAY
AND SECONDS LATER A 737
ROLLS ON AND WAITS
ANOTHER THREE SECONDS BEFORE
THE ENGINES ROAR AND
THE SEMI-OVERWEIGHT WIDE-BODY
LIPS INTO THE OVERCAST
SKY—UP TO THE SUNSHINE
WITH MORE THAN 100 HUMANS
WHO COMPLAIN ABOUT HOW LATE THEY ARE.
I LEAN MY HEAD AGAINST
THE FUSELAGE OF THIS CRJ 900
SHE IS QUIET AND CALM
USED TO THE COMPLAINTS ALTHOUGH
NONE OF THEM ARE HER FAULT
PATIENTLY SHE JUST WAITS
THAT IS HER NATURE.
WE HAVE NEVER MET BEFORE BUT
I KNOW WE'RE FRIENDS
AND I FORGET ABOUT TIME
WHERE AM I GOING?
IT'S OUR TURN NOW AND SHE
TAKES A DEEP BREATH AND
LAUNCHES FORWARD WITH A POWERFUL FORCE.
EVERYTHING IS BEAUTIFUL AND
I CRY BEHIND THE DARK GLASSES
I AM ALIVE.

A CRJ is a small regional jetplane

G650

LOOKING OUT THE BIG
OVAL WINDOW I SEE
AN ALMOST PERFECT WHITE
BLANKET OF CLOUDS GENTLY COVERING
THE EARTH AND ALL THE SCREAMS
OF PAIN AND SUFFERING ARE MUTED,
MUFFLED AND 48000 FEET BELOW.
YET THEY PIERCE MY MIND AND
I AM REMINDED WHY I AM HERE
AT 586 MPH SOMEWHERE OVER THE
PACIFIC—I THINK, I FORGET
BUT THE TWO FEMALE PILOTS KNOW
THAT IS WHAT THEY DO.
—
THE TIME IS 6:37 AM IN NEW YORK
AND TONIGHT I WILL BE HOME
HAVING DINNER WITH MY WIFE
AND OUR LITTLE GIRL
BUT FIRST I HAVE TWO CONVERSATIONS
THAT IS WHAT I DO
I LISTEN. ASK. WAIT.
ONE DAY AT A TIME. UNTIL THE SCREAMS STOP.
NOW IT IS TIME FOR MEDITATION
AND A LITTLE NAP.
I CLOSE MY EYES
EVERYTHING IS LIGHT.
—

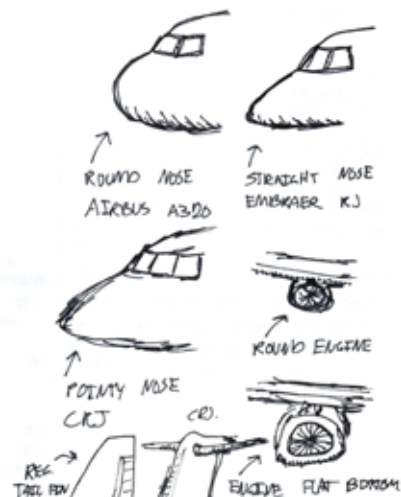

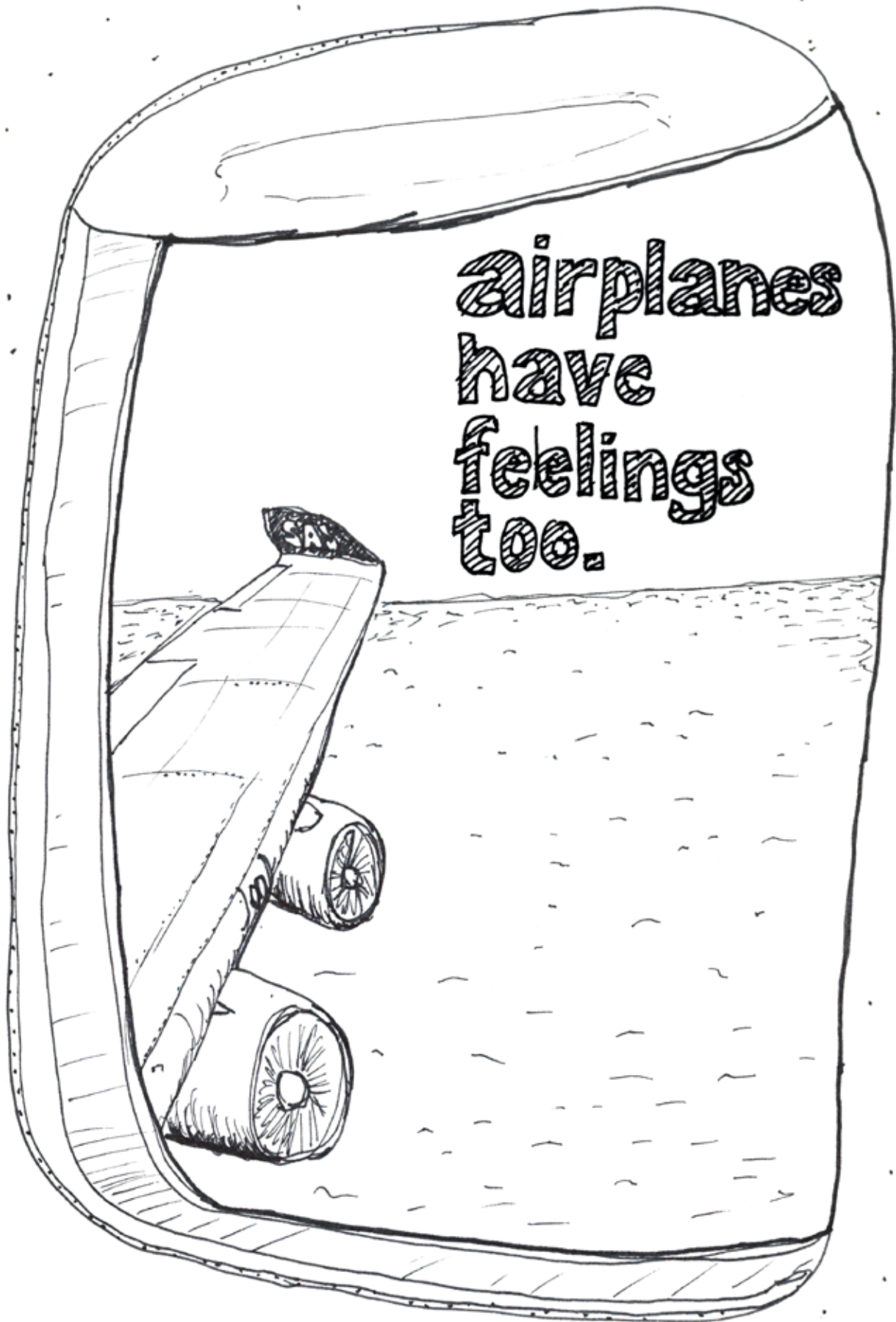

airplanes
have
feelings
too.

Take-off

—
I finally learned to get over my own ego and dared to ask for help. Less than two months later I had launched a new business based on how I ideally wanted to work and live. I had clients and profits and my biggest dream of the past six years had come true. So I dreamed up bigger visions and began to focus on making them come true.

Over the edge

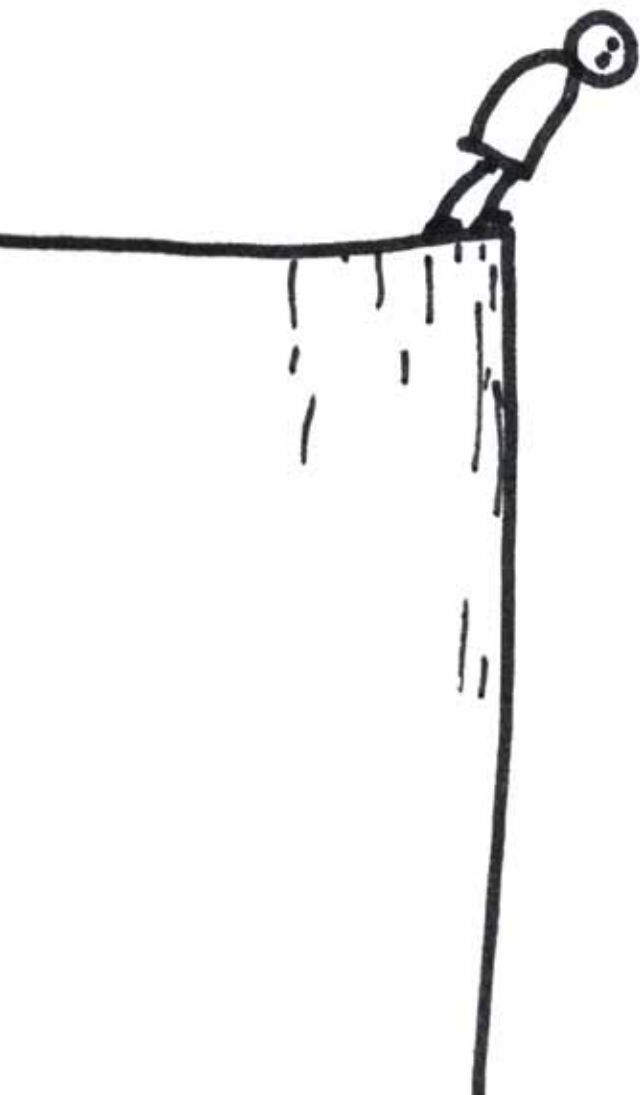

Early 2012 became a crucial wake-up call for me. While preparing my tax returns for 2011 it became increasingly clear to me that my way of life had become completely out of balance with the money that I was not making. In 2011 I had spent about 25,000 USD more than I had made, cutting substantially into my savings. I knew that something like this was likely to happen after moving to a new country and trying to setup a freelance business, however, what was bothering me was not that I had spent the money. The problem was that there was no signs that the trajectory would change. I had still not figured out what exactly I was offering to the world and how could I expect the world to offer me work if I didn't even know what I had to offer? So I had to figure it out. And I'd probably have to ask someone for help. And this was when it happened...

On the following page you can see a page from my notebook on this day.

ME vs. EGO

WHEN YOU ASK SOMEONE TO HELP YOU, DOES THAT MEAN THAT YOU HAVE FAILED? I NEED HELP IN GETTING MY BUSINESS UP AND RUNNING IN A MORE SUSTAINABLE WAY. I NEED HELP FINDING CLIENTS AND PROJECTS. MY EGO DOES NOT LIKE THIS. MY EGO THINKS THAT IF I ASK FOR HELP JUST ONCE, I WILL LOSE MY COOL. PEOPLE WILL SEE ME AS A COMPLETE FAILURE AND THE PEOPLE WHO WERE IN FACT CONSIDERING TO HIRE ME WILL IMMEDIATELY REALIZE THAT IT WOULD BE A BAD IDEA. MY EGO SUGGESTS THAT I KEEP UP APPEARANCES AND PROJECT SUCCESS INTO THE WORLD. THERE IS NO NEED TO MAKE MYSELF VULNERABLE

IT WILL

JUST

BA-

CK-

PT-

PT-

PT-

PT-

PT-

PT-

PT-

PT-

THE TRUTH IS THAT MY EGO HAS ALREADY BEEN RUNNING THE SHOW FOR TOO LONG. I NEED TO SHOW THE EGO THAT I AM IN CHARGE. I DON'T THINK ASKING FOR HELP IS FAILURE. TO KNOW YOUR OWN STRENGTHS AND WEAKNESSES IS VERY IMPORTANT. I HAVE NOT GIVEN UP - I AM STILL SUCCESSFUL AND I CAN STILL CARRY MYSELF WITH PRIDE. I JUST KNOW NOW THAT I NEED HELP IN ORDER TO BALANCE MY ECONOMY, AND THUS IN TURN ACHIEVE MY BIGGER GOAL IN LIFE. THIS WEEK I WILL DEDICATE TO SOLVING THIS ISSUE. AND MAY BE THE NEXT

WEEK

TO

||

||

||

||

||

||

||

||

||

||

||

||

Business model

After getting over my own ego and learning to ask others for help I began to dream up my new business model. Instead of asking myself: what do I have to offer? and coming up with 20 answers as I had always done, I instead tried to answer the question: if I could have it any way I wanted, how would I want to work? It was remarkably difficult to really clearly imagine what I wanted. I couldn't yet see what the actual work would be, but I began to narrow down how I wanted it to happen. Who my ideal clients were. My price model. And also just listing things I ideally didn't want to do. Out of all this, my new company 'Ideas Are Nothing' was born.

This page features snippets from different pages of my notebook.



DECISION-MAKERS
CEOs, FOUNDERS, ETC.
PEOPLE WHO DON'T NEED APPROVAL
FROM ANYBODY ELSE.

\$ + FLOW

CLIENTS PAY A WEEKLY OR MONTHLY FEE. THIS GIVES THEM A CERTAIN AMOUNT OF MEETINGS — NO REFUNDS IF UNUSED.

ROCK 'N' ROLL

MY FOCUS
IN WORK



1:1 GROUP
THE WORK-FORMAT IS ONLY MEETING
EITHER 1:1 OR WITH A GROUP.
I DON'T WORK WHEN THE CLIENT
IS NOT THERE — BUT THE CLIENT
DOESN'T NEED TO KNOW THIS.



I DON'T DO: RESEARCH,
E-MAIL, PRODUCTION, DESIGN
(FINAL), OR ANYTHING THAT IS
THE ACTUAL DOING. MY WORK IS
BEING AND GUIDING OTHERS TO
BE. I DO EXAMPLES AS PART OF THIS.

SPIRITUAL
FOUNDATION

THE POWER
OF NOW

BUSINESS FRAMEWORK
OR JOB WITH INFLUENCE

SKILLS + EXPERIENCE

- ENTREPRENEURSHIP
- SAVIOBOX

BASIC EDUCATION

- UNIVERSITIES

IN MY WILDEST DREAM, MY WORK NO LONGER
REQUIRES ME TO SIT IN FRONT OF A SCREEN OR
TO KEEP UP WITH E-MAILS. ALL MY WORK IS
DONE WITH OTHER PEOPLE, EITHER 1:1 OR IN
SMALLER GROUPS. I DON'T MAKE A PRODUCT I
JUST REMEMBER IDEAS INSIDE SOMEBODY ELSE'S
HEAD. I RELY ON NOTEBOOKS AND GOOD MANAGERS.
I WORK A LOT — MOST OF THE TIME, I LOVE TO
WORK. I HAVE ENOUGH DEMAND AND I CAN
AFFORD TO SAY NO TO CLIENTS. NOT TO BE
ARROGANT — BUT IF THEY ARE NOT OPEN TO THE
SOLUTION OR IF THEY ARE DOING SOMETHING
TERRIBLE THAT I CAN'T SUPPORT. I HAVE
A PRICE-MODEL THAT ADAPTS TO CORPO-
RATIONS, STARTUPS AND NON-PROFITS. MONEY
IS NOT AN ISSUE. I CAN BUY MY FLIGHT
TICKET IN THE AIRPORT — NO NEED TO ALWAYS
PLAN AHEAD. I TRAVEL AROUND TO CLIENTS
SOMETIMES BUT I ALSO HAVE CLIENTS COME
TO ME SO THAT I CAN BE WITH MY
WIFE AND FUTURE KIDS. I GET TO DO WHAT
I LOVE EVERY DAY.

This page is my surprised account from May 11th when I realized that several of my dreams about the ideal business model quickly had come true.



LAST YEAR ABOUT THIS TIME I HAD A CONVERSATION WITH STIVE THAT RADICALLY CHANGED MY LIFE TRAJECTORY. I WAS CONVICTED WITH THE IDEA OF GRAPHIC FACILITATION AND THE IDEA THAT I COULD BE A NATURAL GRAPHIC FACILITATOR. I KNEW THAT SOMETHING HUGE HAD HAPPENED BUT I HAD NO IDEA WHAT IT WOULD MEAN TO ME ON A PRACTICAL LEVEL. A DOOR HAD BEEN OPENED AND I WALKED THROUGH IT. THEN CAME NINE MONTHS OF LEARNING AND PRACTICING AND STRUGGLING WITH EXPLAINING WHAT I DO AND ESPECIALLY STRUGGLING WITH BUSINESS MODELS. I LOVED DOING THE FACILITATION WORK BUT I COULD NEVER GET ENOUGH OR I WOULD HAVE TO DO OTHER WORK TO GET TO THE WORK I REALLY LOVED. E.G. THE FACILITATION PART BEFORE A WEBSITE PROJECT. MY BEST MOVE WAS

WHEN I BEGAN TO UNDERSTAND THAT VISUAL NOTES IN MY NOTEBOOK WERE JUST AS EFFECTIVE AS BIG SCALE RECORDINGS. AND AGAIN IN JANUARY WHEN I REALLY CHALLENGED MYSELF TO RETHINK MY FORMAT AND BUSINESS MODEL. BASED ENTIRELY ON WHAT I PERSONALLY PREFER, E.G. NO EMAIL, CONTINUOUS / MONTHLY ENGAGEMENT, NO RESEARCH JUST THE MEETINGS, AND ONLY WORKING WITH GREAT PEOPLE THAT ARE EITHER FRIENDS OR HAVE POTENTIAL TO BE. WITH THAT CLARITY, AND A LOT OF SUPPORT FROM FABIAN I JUMPED IN, LAUNCHED AND WAS UP AND RUNNING IN A FEW MONTHS THEN CAME THE FEAR AND DOUBT BUT THAT IS ANOTHER STORY. THE DREAM OF HAVING ENOUGH WORK + \$ CAME TRUE AND I GET TO WORK WITH AHA

Another big dream came true



As my dreams of an ideal business came true quite suddenly I also realized something else: for the past seven years my biggest dream in life had been to move to New York and to establish myself and support myself financially. The Green card came true in 2010. We moved in 2011. But it was only in April 2012 that I could finally also say that I was able to properly support myself financially. Think about it for a second. How often do you achieve a goal that you have been working towards for seven years? For me this was a first. It had taken two years more than my M.Sc. and had required substantially larger amounts of effort and investment. But it came true. When that happens, I think there is only one thing you can do: stop and appreciate it. And then...

...keep on
dreaming

Looking into the future

I had made my biggest dream from the past seven years a reality. What was next? For myself I sometimes try to imagine my own future. Not because I think I can predict it, but because I think that a vivid and precise imagination of a compelling vision will make it easier to make it true. On the opposite page I have included two examples of

when I have tried to imagine what the future of my work could look like. They are both quite extreme, and one of them is close to absurd. I basically got the idea that if my clients were the ten most influential people in the world I would most likely have to always fly around the globe to meet them. For obvious reasons I would love to do that,

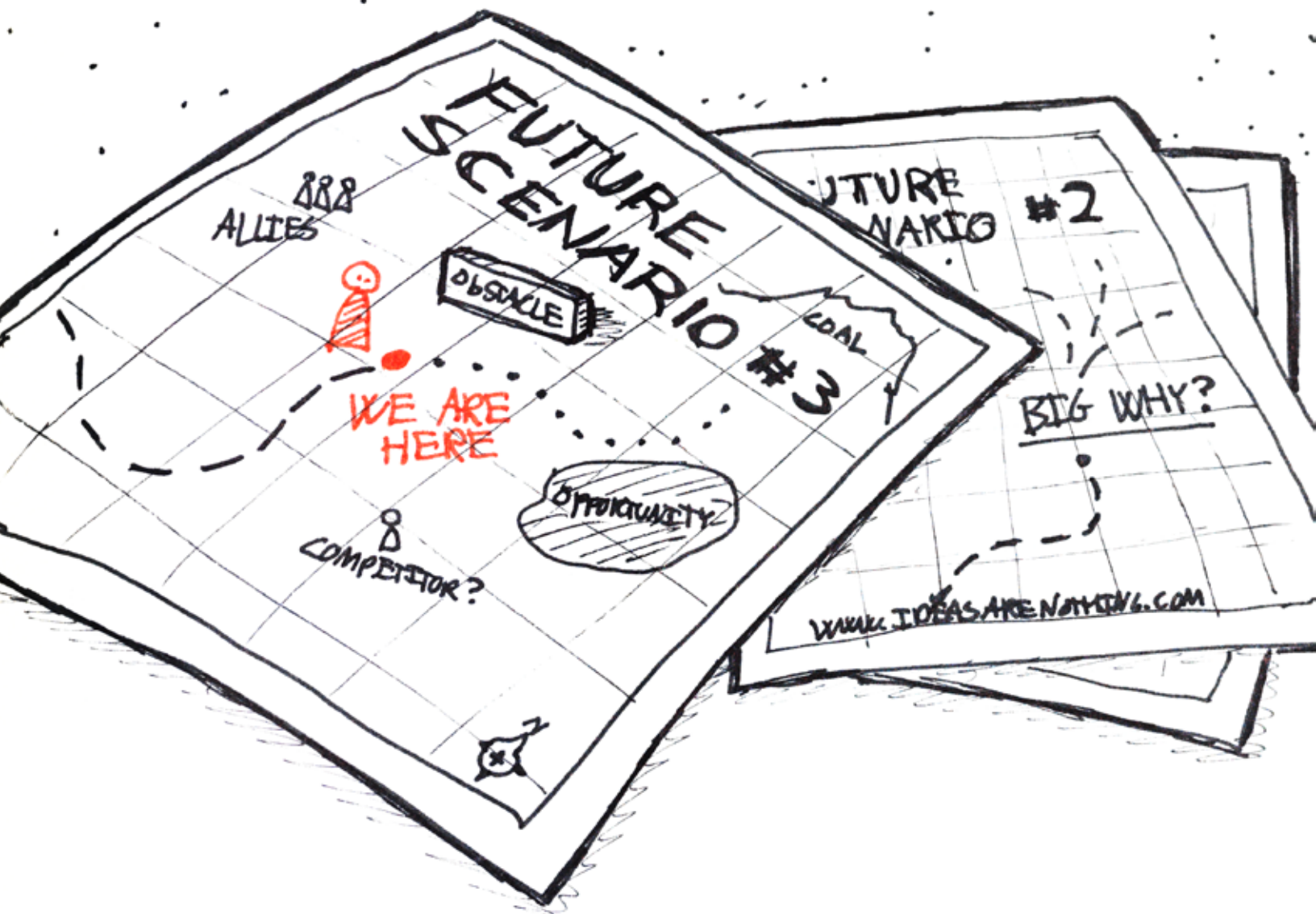

but I also want to have a somewhat normal family life. Then I had an idea: if I were to fly all the way around the globe each week, it would give me either six long days (westbound) or eight shorter days (eastbound). I found that I would rather have eight days of an average of 21 hours and then I tried to make a weekly calendar of how

I could see my family and still have meetings in all time zones every week. In the other case I wrote an e-mail to myself that I would love to receive from Rex W. Tillerson, the CEO of Exxon Mobil in 2014.

THERE ARE 7 DAYS A WEEK. 24 HOURS A DAY. $7 \times 24 = 28 + 140 = 168$ HOURS.

$$\frac{168}{6} = 28 \quad \frac{168}{8} = 21 \quad \frac{168}{9} = 18,06$$

I WONDER IF IT IS ACTUALLY POSSIBLE AND FEASIBLE TO INVENT A NEW WEEKLY RHYTHM WHERE INSTEAD OF SEVEN DAYS OF 24 HOURS A WEEK IS MADE OF SIX DAYS W 28 HOURS OR EIGHT DAYS OF 21 HOURS. IF I LITERALLY FLY AROUND THE GLOBE WEEKLY AND CROSS ALL TIME-ZONES I MIGHT AS WELL JUST INVENT MY OWN AND HAVE MY PLANE, CREW ETC. ADJUST TO IT. A LOT OF PEOPLE COMPLAIN THEY DON'T HAVE ENOUGH HOURS PER DAY, BUT ACTUALLY I THINK I WOULD RATHER HAVE SHORTER DAYS AND THEN HAVE AN EXTRA DAY PER WEEK. THIS IS CRAZY. AND I LOVE IT.

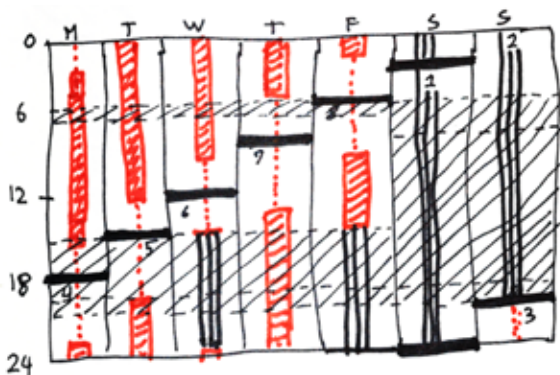

POTENTIAL MEETING/WORK TIME
 TRAVEL/RELAX
 FAMILY TIME IN NYC

E-MAIL MESSAGE

DATE: JUL 8 2014

FROM: REX W. TILLERSON <R.W.TILLERSON@EXXONMOBIL.COM>

TO: MATHIAS VESTERGAARD <M@MATHIASVESTERGAARD.COM>

SUBJECT: ENERGY FOR THE FUTURE

DEAR MATHIAS

I HAVE BEEN WANTING TO WRITE TO YOU FOR SOME TIME NOW. YOUR NAME FIRST CAME UP IN A CONVERSATION WITH WAREEN BUFFER IN 2013 WHERE WE TALKED ABOUT FLYING AND AIRPLANE. HE EXPLAINED WHAT YOU DO - BUT ONLY THEN I WASN'T READY TO UNDERSTAND. IT WAS ONLY LAST MONTH, AFTER I REACHED OUT TO BILL CLINTON TO SHARE MY NEW VISION AND GET HIS INPUT THAT HE REFERRED ME TO YOU AGAIN. AND I BEGAN TO UNDERSTAND. AT LEAST ENOUGH TO KNOW THAT I WOULD LIKE TO MEET YOU.

I KNOW THAT THE FUTURE WILL NOT RUN ON OIL, AND I BELIEVE THAT WE, HERE AT EXXON MOBIL, SHOULD BE LEADING A WAY TO THIS. I DON'T KNOW HOW. BUT I KNOW THAT I WANT EVERY PERSON, EVERY SHAREHOLDER AND EMPLOYEE TO FULLY UNDERSTAND THAT WE ARE ALL PART OF THIS AND THAT WE MUST URGENTLY BEGIN THIS TRANSITION. OUR WASHINGTON LOBBYISTS MUST PUT PRESSURE ON OBAMA TO SIGN THE CARBON TAX AND TO ENSURE THAT THE 10% ANNUAL TAX INCREASE IS ENFORCED. OUR EMPLOYEES AND SHAREHOLDERS MUST COME TOGETHER AND BUILD NEW SOLUTIONS. AND SO MUCH MORE. BUT I AM AFRAID AND CONFUSED WHERE TO START. I WOULD LOVE TO DISCUSS THE PROJECT AT YOUR EARLIEST CONVENIENCE. I TRULY LOOK FORWARD TO MEET YOU. ALL THE BEST

REX
 CEO, EXXON MOBIL GLOBAL

P.S. WE ARE FAMILIAR WITH YOUR TERM AND CONDITIONS AND HAVE NOTHING FURTHER TO ADD. ONCE A MEETING IS CONFIRMED I WILL SIGN THE CONTRACT AND SEND TRAVELPAGES.



All my life I have been jumping from one activity to the next. LEGO. Drawing. Computer games. Programming. Web development. Fashion. Photography. Entrepreneurship. Studies. Video. Teaching. Coaching. Graphic design. Writing. I've been a jack of all trades and it has been a lot of fun to play so many different roles and to learn so many different fields and skills. But there is a limit to how successful I could be so long as I would leave a discipline just as I had gotten a hang of it. Mentors and friends have often given me the advice that I should learn to 'focus' – find one thing and stick with it. I hated when people told me that. I hated it because I knew they were right. And yet they were also wrong. Because although I couldn't see it and although I couldn't explain how, I knew that one day it would all come together. Yes, I had to focus. But not too soon. Not before I had found the right thing. Now I think I may have found it. Or I am at least getting very very close. For all the time I can remember I have always known that whatever I was

doing was not something I wanted to do for the rest of my life. I knew it when I made websites. I knew it when I was a photographer. I knew it when I was in fashion. I just knew that I had to do it and do it properly for a while, but that it would eventually come to an end. And it always did. With the work I do now I still don't know if I want to do it for the rest of my life, but I know something. I know that the certainty of not wanting to do it, is gone. I no longer know that I don't want to do it. And yes, I can in fact imagine myself doing this at 85. This clarity has helped me focus on many levels and it is an incredible feeling. Yes, I still do a photography job once or twice a year when old clients call. Yes, I still help a friend get a website up. But I'm no longer trying to sell ten different things. Now I know what type of work I really want to do. And I do it. And I sell it. And I love it. On the following pages I have included very different examples of how this new focus has influenced my life.



THE QUEST IS NOT TO FIND ONE PERFECT WHITE SHIRT BUT TO ALLOW MYSELF TO INVOLVE IN A VARIETY OF NICE SHIRTS THAT I LIKE. BASED ON THAT EXPERIENCE I CAN ALWAYS LOOK FOR MORE.

I WILL LOOK IN THESE STORES/BRANDS:
-JILL SANDER, OC, PROJECT NINE, KILOV,
BERGDORF, STENSTRÖM, UNIQLO,
MARGIELA, BEHAVIOR, BEKONS BROTHERS,
PRADA

Finding focus in my format

A simple visual evolution of the notebooks I used in 2011 and 2021. From many different formats, sizes, colors and brands to a completely uniform and standard black, soft cover XL Moleskine.

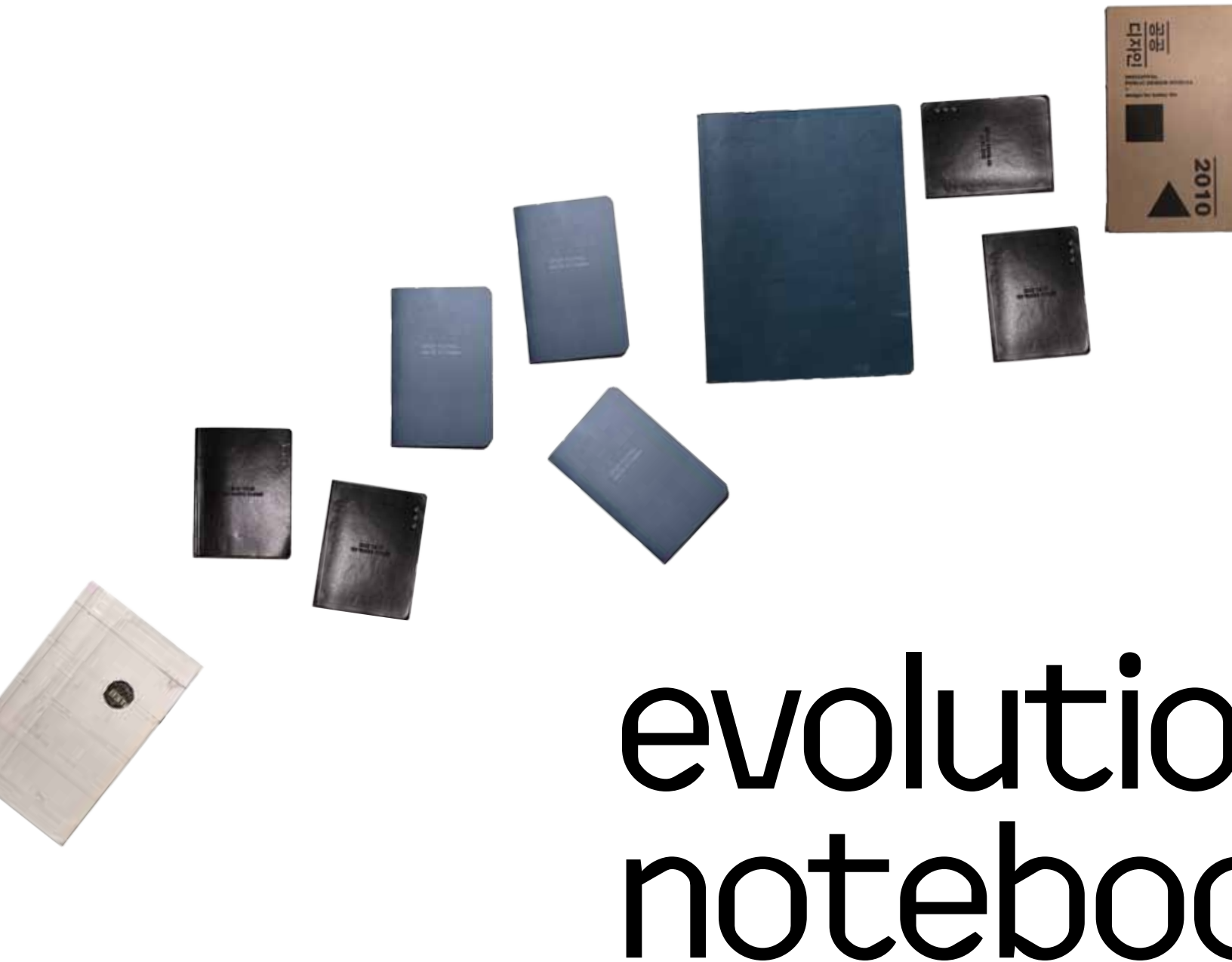

evolution notebook

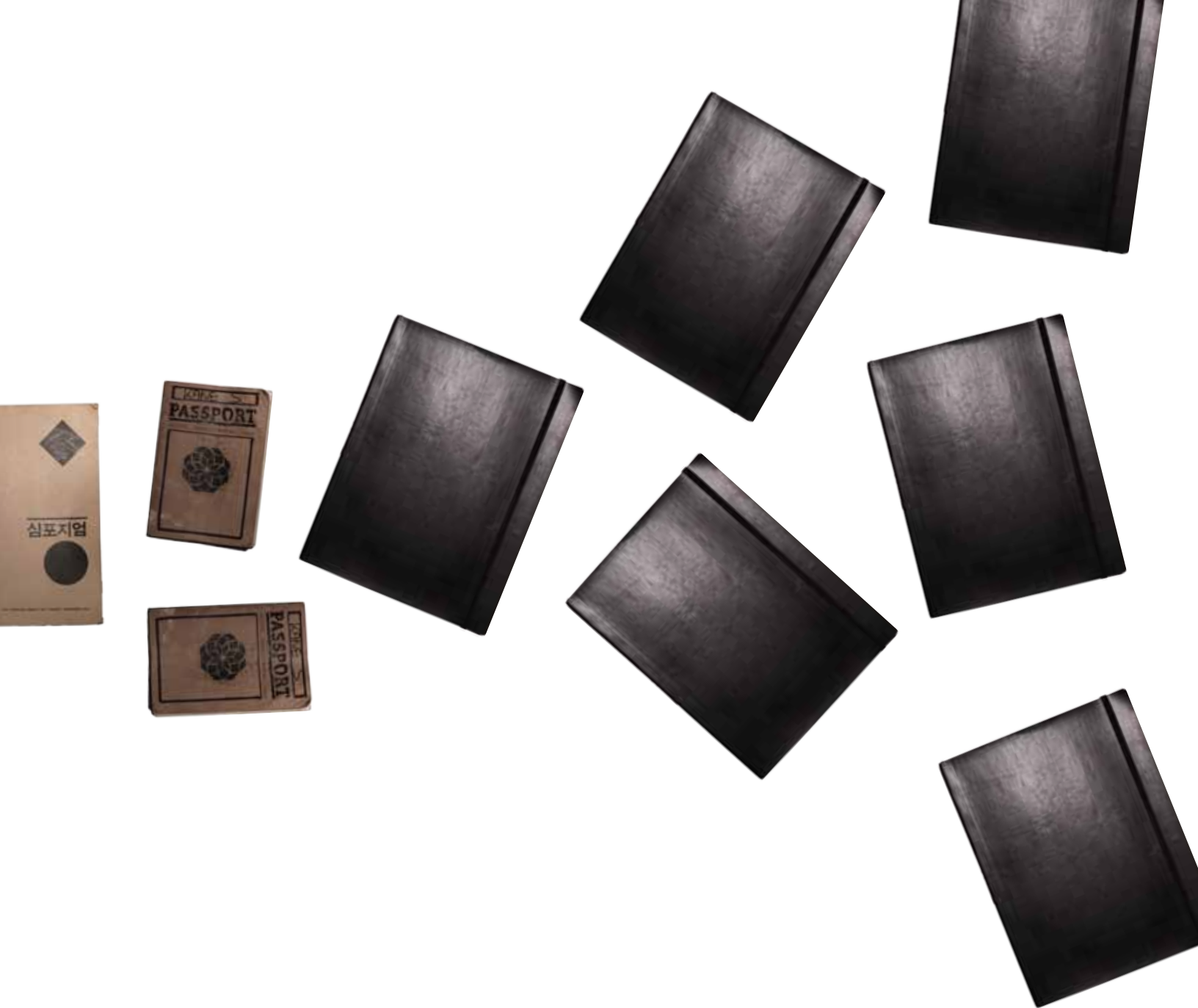

on of the oks

Emerging formats

By doing the same type of work over and over each week I have noticed how certain patterns begin to emerge inside my notebooks as well. On Mondays I make an increasingly visual overview of the clients and other projects I need to tend to in the week ahead. On this spread you can get a sense of the evolutionary process.



March



May



June



July



August



September

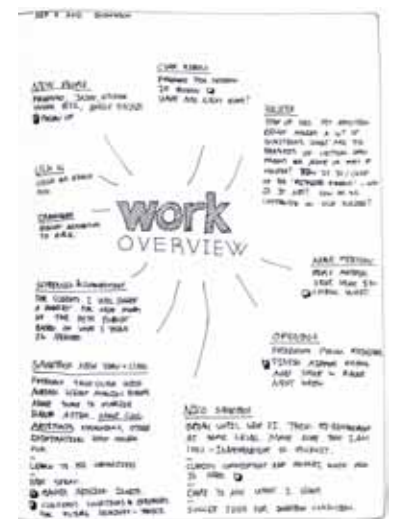

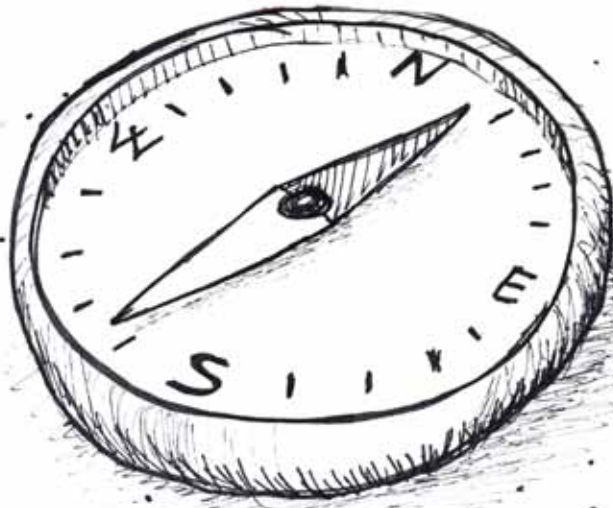

October

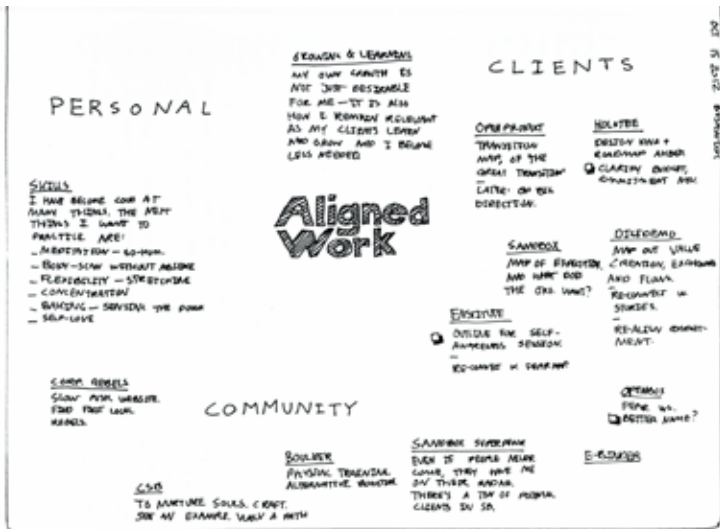

December

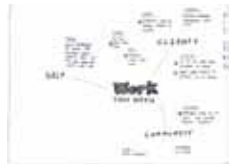
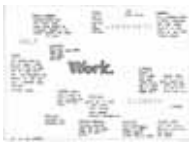

November



Intentional

—
In whatever I did, I often asked myself “why am I doing this?” and reflected on how I could best do it in order to learn, to grow or just to enjoy. I learned to break and make habits and to consciously choose what habits I wanted. I manifested my values in objects, faced deep fears and created guidelines for myself. I baked 100 loaves of bread.

Goals that I set in the beginning of the year

Early this year I made this simple list of three things I wanted less of and three opposites I wanted more of. Without necessarily consulting this list each time I had to make a decision, it still somehow became a self-fulfilling prophecy.



LESS



MORE

=



ME! ME! ME!



US & WE



DOING & PUSHING



BEING



HEAVY RESPONSIBILITY



FLYING & LIGHTNESS

Making and breaking habits

I think habits are great. They provide structure to my daily life so I can focus on what I think is most important. They are everywhere. Sleeping habits. Eating habits. E-mail habits. However, habits can also be leading to undesirable behavior. I used to have e-mail habits that made me miserable. I used to be addicted to coffee. I used to find it hard to get up in the morning. But this year I really learned to become aware of my many habits, break the ones I didn't like and replace them with different ones that I enjoy more. Right now I have a bizarre habit of taking ice cold showers in the morning. It has taken months of practice but now I really enjoy it. A lot. But the point is not if cold showers are good or just stupid. The point is that anything is possible. That's what I remind myself of.

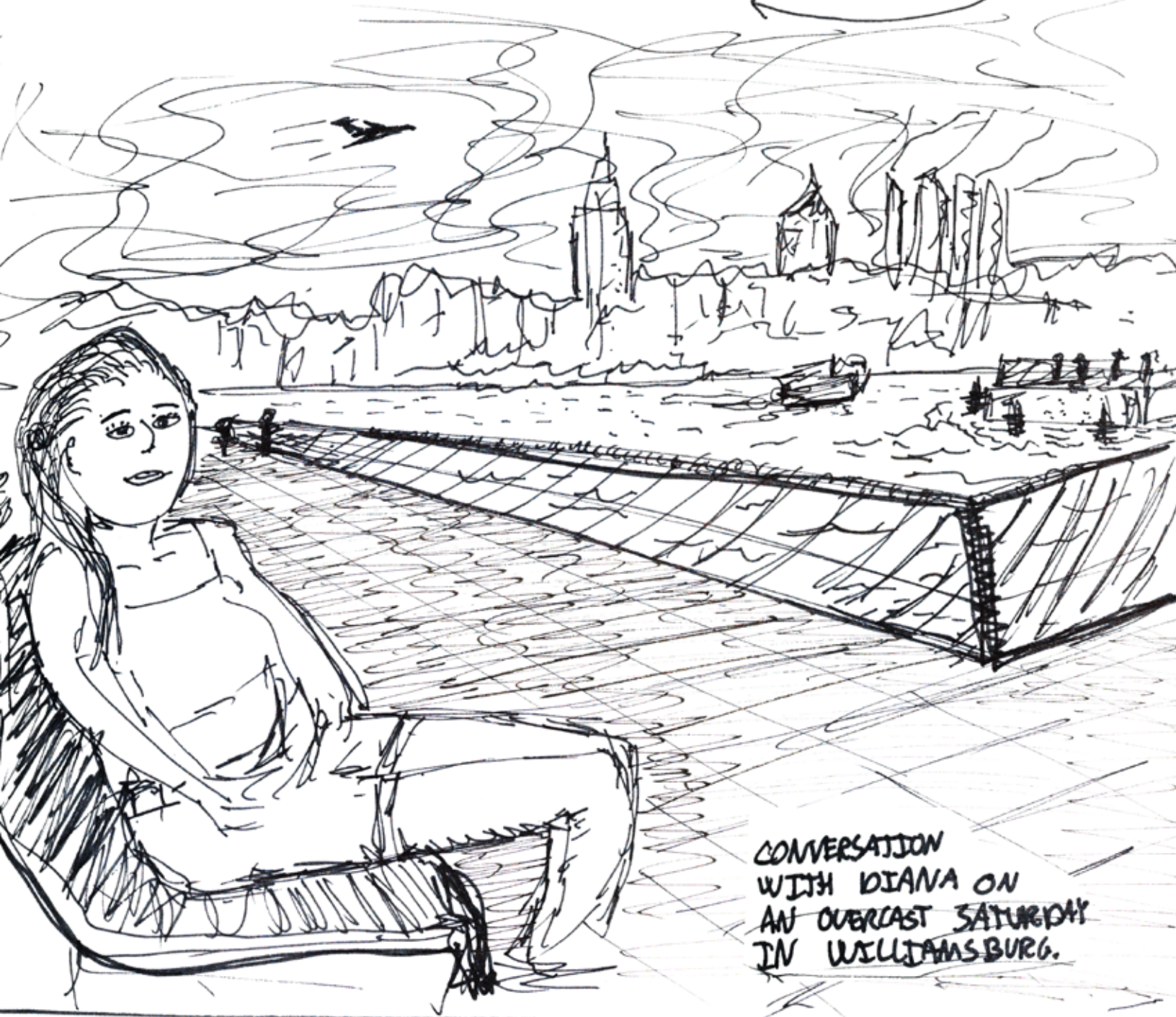
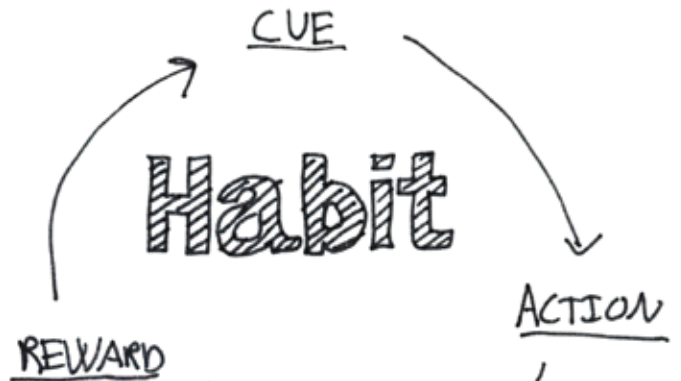

CONVERSATION
WITH DIANA ON
AN OVERCAST SATURDAY
IN WILLIAMSBURG.

Becoming fully me

Things can be said with many words or few words.
Sometimes with no words. One day I used an entire page
in my notebook and wrote:

100%

Guidelines

GO OUT OF MY
WAY TO MEET
PEOPLE IN PERSON,
E.G. IN PRICE/COST -
BUT DON'T LET IT
BE A SACRIFICE.

ENJOY WHAT I DO
BY FOCUSING FULLY ON
ONE THING AT A TIME

Guidelines FOR MY LIFE.

BE MINDFUL IN
CREATING HABITS
AND PATTERNS.

DON'T BUY
STUFF THAT
YOU WOULDN'T
HAVE IN YOUR LIFE
IF YOU WERE A
MULTI-BILLIONAIRE.

LESS EFFOR

MAY 2 2012 PROJECTIVE SPACE

things that mean something



WEDDING RING

COMMITMENT

TO MYSELF, TO US, TO WE. TO MAKE AN EFFORT. TO KEEP FROM MY BRAT



WRIST BAND

STRENGTH

BOTH MENTAL, SPIRITUAL AND PHYSICAL. THEY INTERPLAY AND MIRROR EACH OTHER. PHYSICAL TRAINING CAN MAKE ME MENTALLY STRONGER AND VICE VERSA.



COUPLE'S RING

BALANCE IN ASSYMMETRY

TO REMEMBER THAT BALANCE IS NOT ALWAYS TO BE EQUAL. THAT THE INTERPLAY BETWEEN STRONG MASCULINE AND FEMININE ENERGY CREATES DYNAMIC FORCE.



TORNADO BOOTS & RICH OWENS COAT

LEAVING INTO FEAR

FEAR OF ROACHES. FEAR OF POORRY. I CAN LIVE ON MY EDGE AND LEAN INTO IT.

I have a lot of ideas and beliefs in my head. Ideally I try to live and enact them every day and let them be reflected in my actions. To help me do this I often write them

down. But some of the most core beliefs and insights I like to invest into certain personal objects that I often have with me.

Role models

I find it easy to talk the talk. To read inspiring books and discuss eastern philosophy on a theoretical level. Much harder is it when I try to live it. To let the ideas become who I am. But ultimately it is also the only way it can ever really make sense. One way I make it easier for myself

to act out my beliefs, is to find vivid role models like Dale Cooper from Twin Peaks or the Jedi Knights of Star Wars. In challenging situations I then ask myself "What would a Jedi have done?" and that way it is much easier to come up with a creative solution.

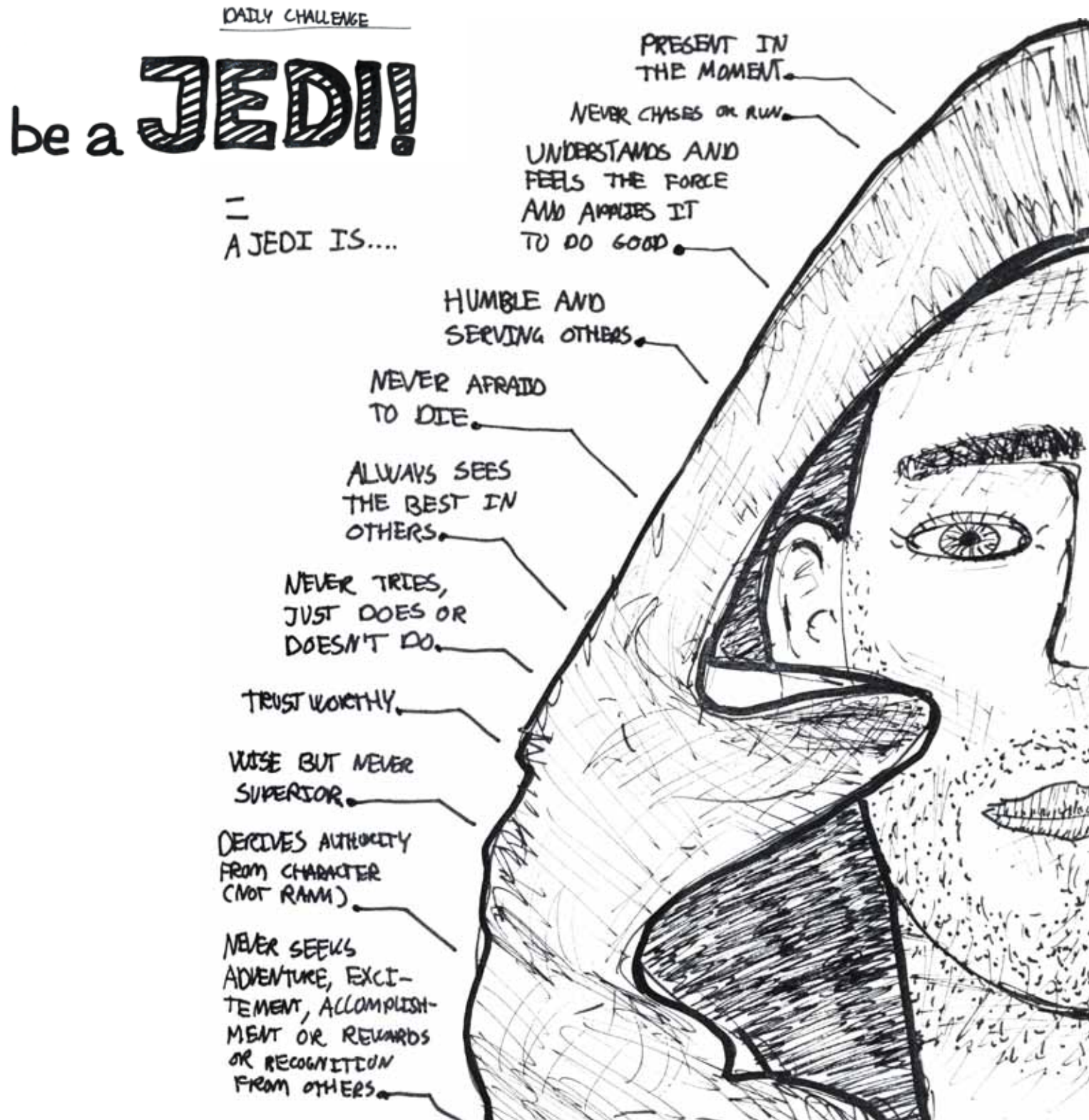

Dealing with stress and facing my deepest fears

After my initial head to head with my ego I probably thought that it would be over. However, 2012 has been a year where I have faced much more than my ego. I have also become aware of several patterns of stress behavior that I have learned through the years. Automatic responses to certain situations. It's like having a monster in the stomach. When it is sleeping everything is

fine, but when certain things happen the monster wakes up and takes over the controls. This spread includes several pages from my own process of gradually becoming aware of these patterns and slowly turning negative events into opportunities to break these old patterns and free myself.

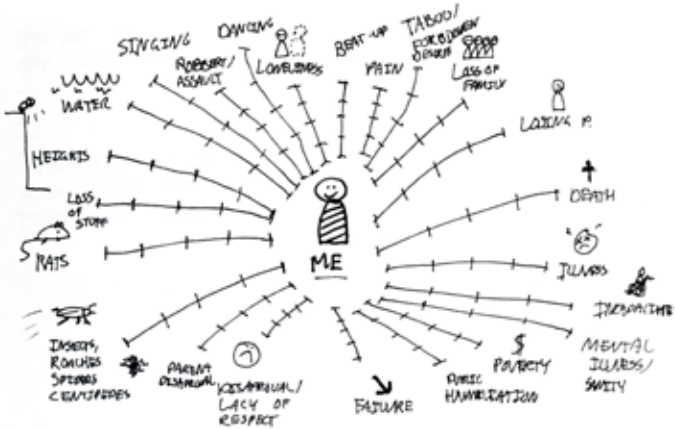

GOTO

EGO
POWERFUL ALLY
 =
 FOR THE PAST MANY YEARS I HAVE LIVED WITH A MONSTER INSIDE ME. A MONSTER THAT I WILL CALL THE 'PAIN BODY'. OVER THE YEARS, PAIN, SUFFERING AND NEGATIVE EMOTIONS HAVE ACCUMULATED IN THIS NEGATIVE FIELD OF ENERGY. FOR MOST OF THE TIME THE MONSTER HAS BEEN PASSIVE, BUT EVERY SO OFTEN IT COMES TO LIFE AND IT HATES ITSELF MY REVENGE. ONE DAY I BEGAN TO ACCEPT MY CYCLIC BEHAVIOR AS 'NATURAL' - 'NO ONE WITHOUT PAIN!' BUT IN FACT I JUST IDENTIFIED MORE WITH THE MONSTER. NOW I FINALLY UNDERSTAND THAT THE MONSTER IS NOT ME AND THAT THE REAL ME CAN ACTUALLY DO SOMETHING ABOUT IT. I CAN NO LONGER ACCEPT LIVING WITH A MONSTER. I CAN NOT ACCEPT THAT A MONSTER IS

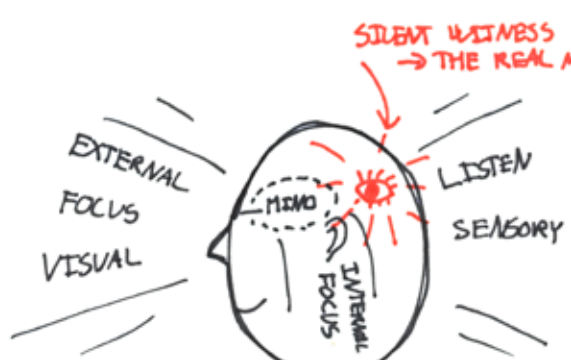

=
 MY MIND KEEPS TRYING TO TAKE MY ATTENTION, AND I STILL GET THESE LITTLE ATTACKS OF FEAR WITH INCREASED HEART RATE AND SWEAT AND I HAVE A HARD KNOT IN MY STOMACH. MY SUCCESS IN BUSINESS AND LIFE DEPENDS ON MY ABILITY TO REALIZE THAT MY BODY AND MIND ARE NOT THE ACTUAL ME. WHEN I CAN STEP BACK AND JUST BE THE SILENT WITNESS OF BODY AND MIND THEN FEAR OF FAILURE/LACK OF RESPECT I CAN BE FREE ANXIETY

MY JOB IS TO CONTINUALLY MAKE AN EFFORT TO BE PRESENT AND ALIVE AND APPRECIATIVE. THEN EVERYTHING ELSE WILL WORK OUT.
 HEAT ATTACK SWEATING + INCREASED HEART RATE
 THE POWER OF NOW IS A GOOD GUIDE. MY ABILITY TO DISSOLVE NEGATIVE ENERGY IS SOMETHING I WANT TO TRAIN. IF I CAN GET REALLY GOOD AT THAT THEN THERE IS NOT MUCH ELSE TO DO.

CHAI

ACTIVATED BY STRESS IN RELATION TO PERFORMANCE ANXIETY, TAX-STUFF AND OBLIGATIONS

THE 'PAIN BODY'

EARLIER MY 'PAIN BODY' WOULD MAKE ME ILL FOR DAYS UNTIL I GAVE IN AND ACCEPTED

BY TAKING OVER CONTROL THE PAIN BODY SEEKS TO PRODUCE MORE STRESS AND ANXIETY.

MOST OF THE TIME IT HAS BEEN MASSIVE.

GETTING IN MY WAY. I UNDERSTAND THAT IT MIGHT TAKE TIME AND PATIENCE AND ENERGY TO DISSOLVE THE 'PAIN BODY' BUT THAT

IS OK. FIRST STEP IS TO SEE IT AND ACKNOWLEDGE THAT IT IS THERE. MAYBE I CAN RECENT ALICES IN LOVE AND CHAI? I CAN DO THIS

WHAT IS THE WORST THING THAT CAN HAPPEN?

MAY 22, 2012 GUSHAIK



THIS IS SO AWESOME. ALL OF THESE THINGS ARE POSSIBILITIES FOR ACTION FROM MY TRUE SELF - AND OF COURSE NOT ACTION IF I CAN'T FEEL IT IS WORTH LEAVING BEHIND THE MOST LIFE APPROACH (ACTION) NON-ACTION TO TAKE?

Baking 100 loaves of bread

In August I found the bread I have always wanted to eat. My wife's step dad had baked it himself, following a long and detailed recipe from Tartine Bakery in San Francisco. Upon return to New York City I ordered the book and began experimenting. It was very difficult to get it right and

I decided to bake 100 loaves to practice. As I went along the results became better and better and in November I baked loaf no. 100. I'm still no master but it gives me great joy to make and bake bread and to share it with friends and random homeless people on the street.



Integration of goals

This is an attempt to map my different goals in life. Some goals are big goals but also too abstract to be actionable and too vague to be measurable. Others are small and precise but only make sense because they are merely indicators or enablers of other goals.

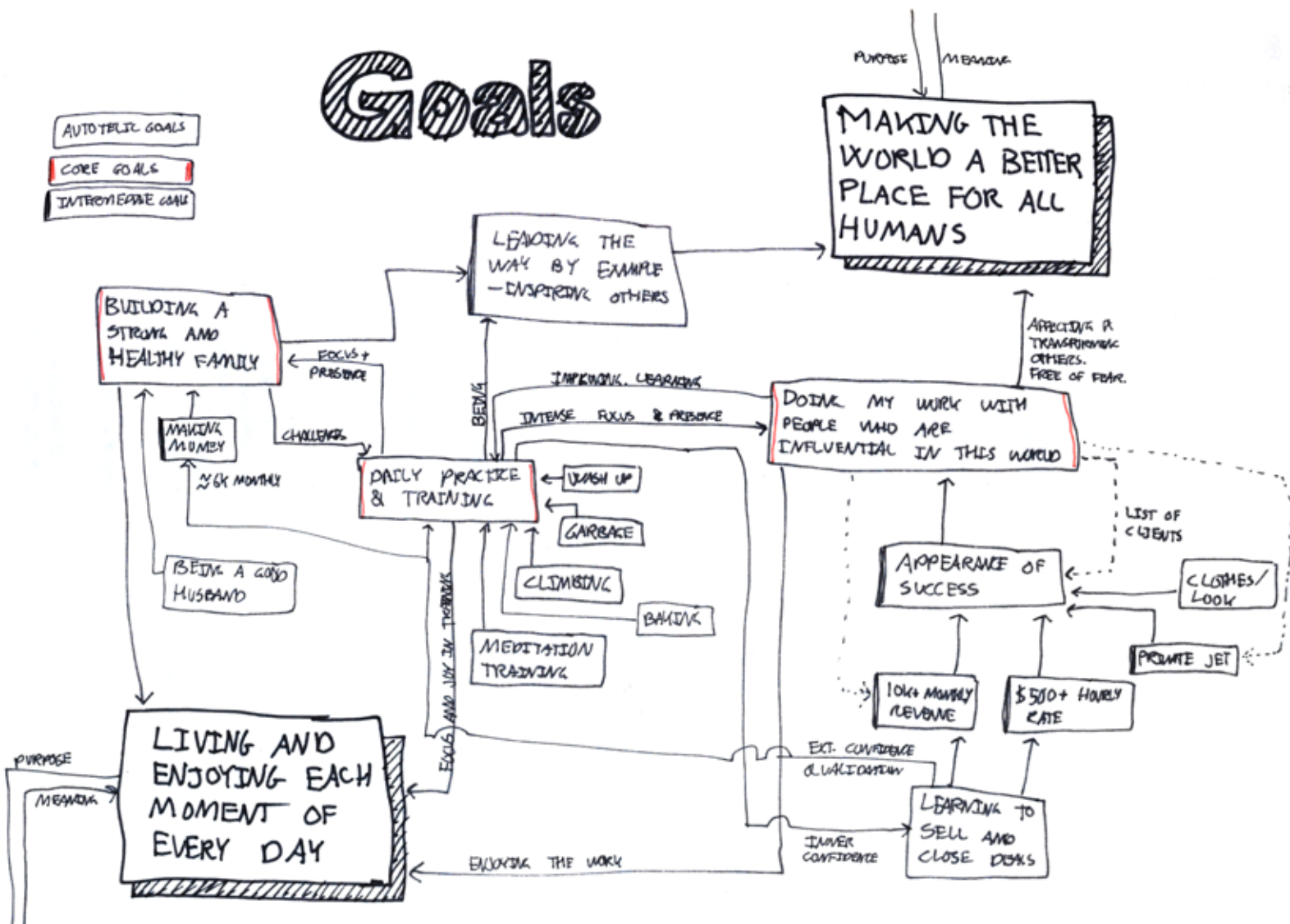

Books I have enjoyed

Small is Beautiful

I particularly loved this collection of essays because they challenge some of our current economic thinking by asking very basic questions about our real goals for society. In current economic thinking the goals are growth and wealth, but how would we design our economy if we started with goals like happiness and safety? Especially the essay on Buddhist economics is a classic. And this book was not written by some granola eating tree hugger. E.F. Schumacher was an old school economist who was serving as Chief Economic Advisor to the UK National Coal Board for two decades.

Tools For Conviviality

I love books that challenge my ideas. Even if I'm not fully convinced I love that a good argument can at least make me question some of my assumptions. Ivan Illich argues that we would all be happier if nobody could ever travel faster than the speed of a bicycle. A city bus or subway may be ok, but trains, planes, trucks and private cars, he argues, does more harm than good. As much as I love flying, I think he is actually on to something. Read for yourself and let's discuss next time we meet.

Good To Great

A classic in the realm of management literature, Good To Great is an inspiring study of the few companies in the world which managed to transition from an extended period of following the general market and competition and become companies that beat the market more than four times and to maintain that for an extended period. What were the changes in these companies that allowed the company to make this transition? The text is inspiring and well written and the findings are illuminating. While I find many of them to be common-sensical, this study shows how hard it can be to follow in real life.

Flow. The Theory of Optimal Experience

Based on the past few decades of research in psychology, Csikszentmihalyi is able to describe in words the ephemeral sense of well-being that can happen when you are fully focused on a particular activity. He distinguished between pleasure, which is based on satisfying bodily needs like food, rest and sex, and enjoyment, which is the thrill of taking on an appropriate challenge that requires all your skill and focus. Reading this book has made me aware of the way my parents have raised

④ HEDGEHOG CONCEPT

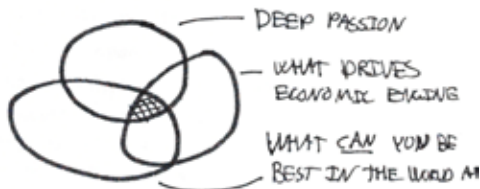

BASED ON DEEP UNDERSTANDING AND NOT JUST USEFUL, IMAGINATIVE THINKING, THE HEDGEHOG CONCEPT IS SIMPLE, AND EASY TO UNDERSTAND. ITERATIVE PROCESS BASED ON VIGOROUS DEBATE. STICK TO IT.

The hedgehog concept from Good To Great

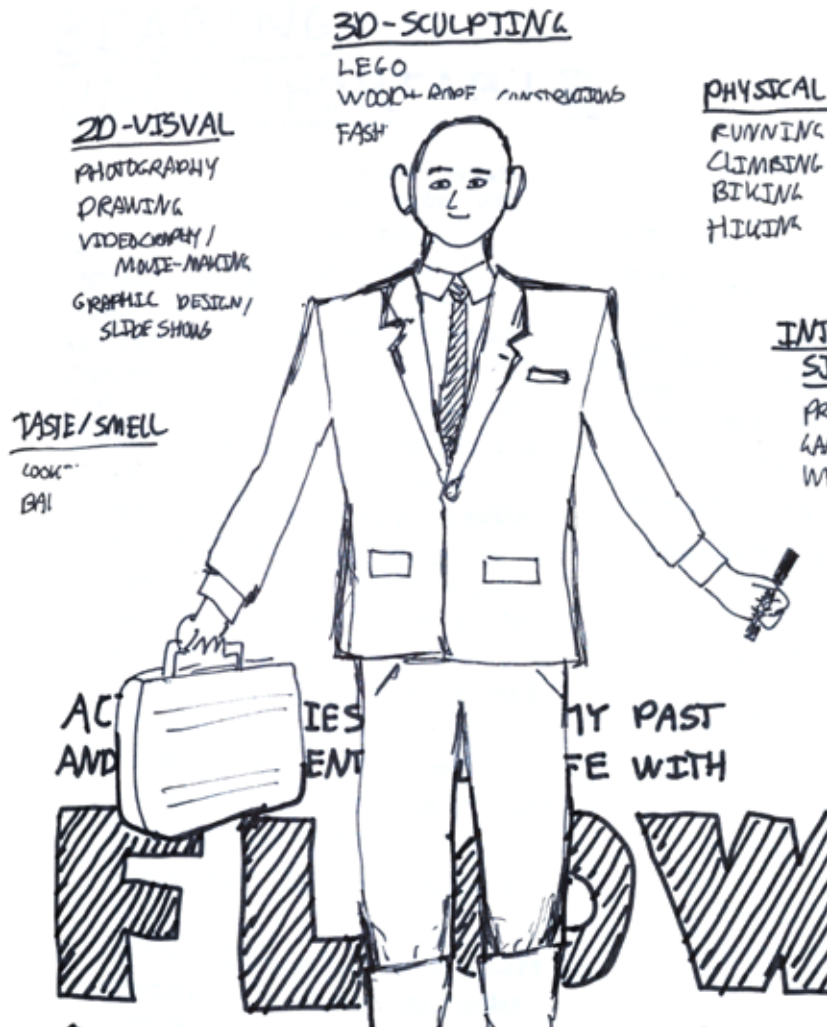

me and how it seems that since very early in my life I have had plenty of opportunities to experience flow. In fact, most of what I've done have in many ways been pursuits of this. However, the book also allowed me to better understand the mechanics of this experience I've already had so many times, which has helped me make little adjustments in my daily life and in the way I do things, in order to make them more enjoyable. I highly recommend this.

Switch

How to make change? If you're the CEO of a company you get to decide and people have to follow your command. But what if you are trying to make change without being the formal leader? Or even if you are the CEO, how do you actually make sure that change can happen? This book creates a very simple framework for how you can approach this in the form of an analogy to a rider on an elephant. Sometimes change doesn't happen because you know what you should do (stop smoking, start running) but you are not motivated. The rider knows but the elephant doesn't move. Other times you are very motivated (the new bold vision for your company) but it's hard to know where to begin. The book gives plenty of good stories that are both entertaining and memorable.

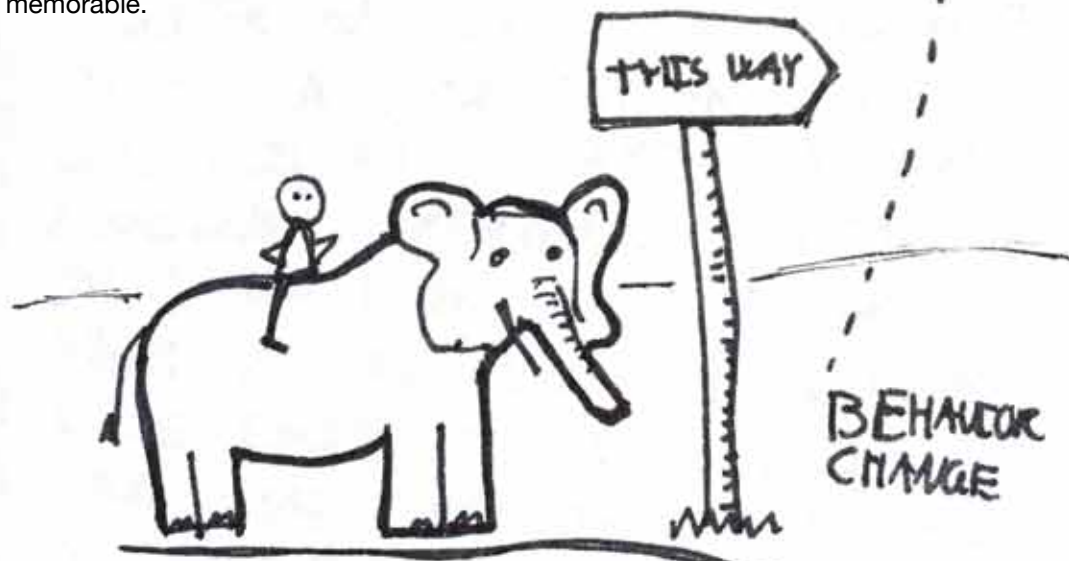

- ① DIRECT THE RIDER
- ② MOTIVATE THE ELEPHANT
- ③ SHAPE THE PATH

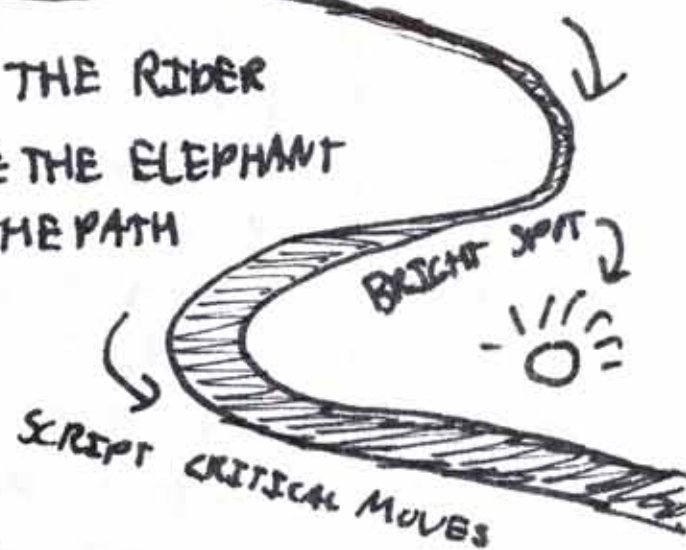

MOVEMENT

INTERACTIVE / SIMULATION

PROGRAMMING
GAME DEVELOPMENT
WEBSITES / APPS

PERFORMATIVE

TALKS
TEACHING

Books I have enjoyed

Making Good

My friend Dev wrote this little gem about finding meaning and money in what he calls the new Making Good economy. It's equal parts self-help and personal story and I found it good because it helped me articulate things I have experienced and gave good advice on how to proceed.

The Way Of The Superior Man

I have an ambivalent relation to self-help books. On the one hand I think they can be incredibly stupid and say all the right things that are so hard to do. Thus, reading self-help books does not in itself guarantee anything. However, on the other hand I've also read more than a few books in this realm that I have greatly enjoyed and which have helped me grow and become more myself. The title of this book is surely not modest, but it really inspired me and was a propelling force in my personal growth this year. It was especially good in helping me understand and connect with a deep sense of masculinity that I have rarely experienced before.

Strong & Fearless

This book says a lot of the same things as The Superior Man. Some people will like the quasi-scientific attitude of this, e.g. not just saying "you should breathe with your diaphragm instead of your chest" but goes into explaining why this makes sense through the anatomy of the lungs. Stuff like that helps me remember and motivates me because it's not just advice but it feels grounded in something. However, the book itself is not super well written and sometimes it's surely more quasi than scientific. I would only read it if you're already highly motivated to make changes in your life and just need more details and instruction on how to do it. I learned a lot of great stretch exercises in this book that I do every single morning now.

The Pleasures and Sorrows of Work

By closely examining how work actually takes place, Alain de Botton weaves eight wonderful tales of our current society as seen from a very different perspective. How does biscuit manufacturing take place? When a pack of tuna steaks says "line caught" then who are the people that catch the tuna and how? How does the everyday life of a rocket scientist look?

The Art Of Travel

Why do we travel? How do we do it? Alain de Botton explores this phenomenon and writes about it beautifully. This was the book that inspired me to write poems and make more drawings again.

How Are Things

A man goes to a party and an acquaintance asks him "how are things?" After this the question will not leave his mind. Things? How are they? So he wrote this philosophical experiment where he attempts to answer this question. It's worthwhile reading because some of his descriptions allowed me to see my own world in a new and more interesting light.

The Places In Between

Rory Stewart walked through Afghanistan in 2002, shortly after the American invasion. It's an incredible tale with rich descriptions of the people and customs in a part of the world that we all hear about in the news but never get to see up close like this.

FICTION

Norwegian Wood
The Great Gatsby
Heart Of Darkness
The Manual Of Detection

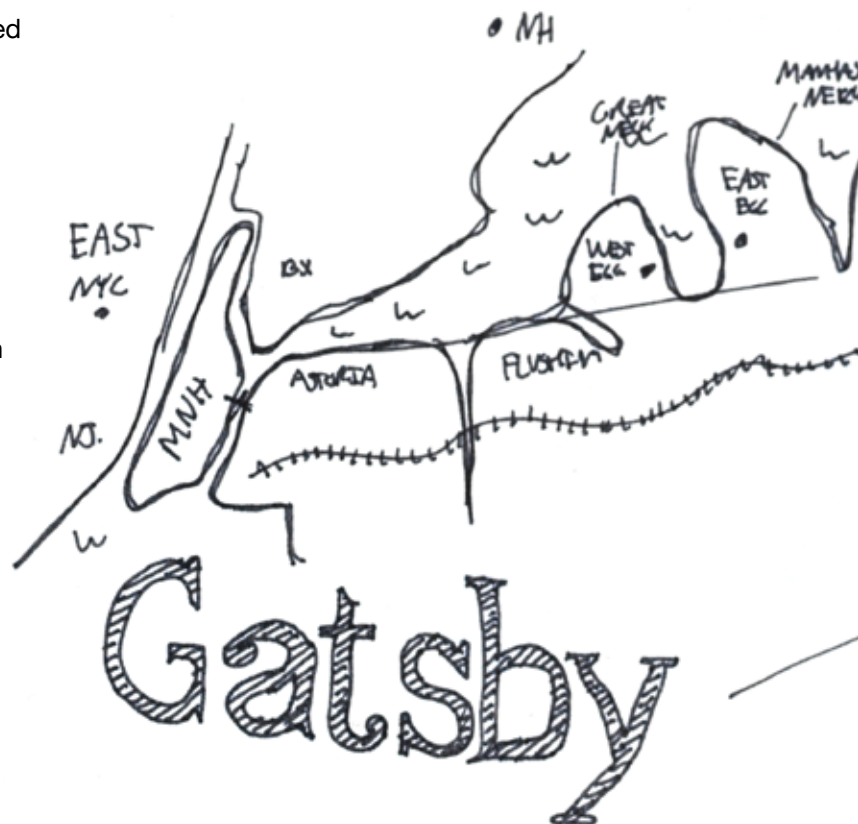

THE WILD

THE SAVAGES, WILDERNESS
 FEAR, HIDDEN EVIL, DARKNESS
 THE FOREST BARBARIC EXIST. P.31
 "PREHENSIBLE MANY CURIOUS, PRACTICAL, WELL-KNOWN?" P.32
WHERE IS THE REAL DARKNESS?
OUTSIDE? INSIDE?

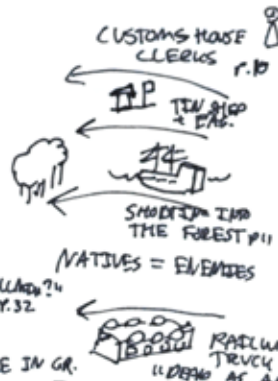

"THE NOBLE CAUSE"

CAUSE OF PROGRESS
 "LET IN ON A CONSPIRACY" P.8
 DOCTOR GLORIFIED BUSINESS
 BUT DOESN'T WANT TO GO. P.8
 - COMPANY RUN FOR PROFIT? P.11
 EACH STATION AS ROAD
 TUMPKS BETTER. P.29

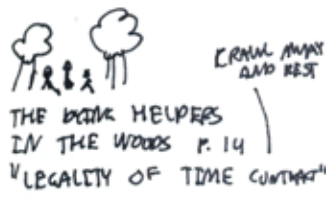

OF DARKNESS

"I WAS PART OF THE GREAT CAUSE" P.13
 "REAL PROGRESS" RED DOTS P.9
 "WAS PART OF THE GREAT CAUSE" P.13
 "REAL PROGRESS" RED DOTS P.9



CIVILIZED

WHITE MAN: "IN THE GREAT DEMOCRATIZATION HE KURT UP APPEARANCES." P.15
 "HE HAD TRULY ACCOMPLISHED." P.17
 "TO MAKE MONEY OF COURSE"
ARE THERE ANY MARKS?
WHERE DOES THE ASSASSINATION EN

MARLOW

"WE KNEW WE WERE FATED TO HEAR ONE OF MARLOW'S INCONCLUSIVE EXPS." P.5



MARLOW

"FOLLOWED THE SEA" (P.3)
 NOT TYPICAL - MEANING OF EPISODE IS NOT A KERNEL INSIDE BUT OUTSIDE.
 "WE LIVE AS WE BREAM-ALONE" P.24
 "I DON'T LIKE WORK - CHANGE TO FIND SELF" P.25
 EVIL = TRUTH
 STRENGTH AS ACCIDENT (P.24)
 "MEN ENOUGH TO FACE THE DARKNESS"
 CONQUEROR vs. COLONISTS (P.4)
 DEVOTION TO EFFICIENCY.

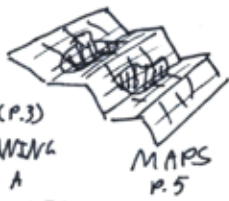

THE BIG MAP WITH COLORED PINKS. P.7

FROM BLANK SPACE TO DARKNESS

CHARMED BY THE SNAKE P.6

POSE LIKE A BUDDHA P.4

KURTZ

10 x IVORY
 "EMISSARY OF CIVILIZATION, SEEMING PROGRESS" P.22
 CHIEF OF CENTRAL ST.
 "TURNING BACK MARLOW'S HQ" P.21
MOTIVE?

Summing up and looking ahead

—
**My biggest successes and a few final thoughts
about the future.**

Summary

My biggest successes in 2012:

_I created my own dream job that I enjoy

_I finally made a huge dream come true: living and supporting myself in NYC

_A new sense of freedom to break and build habits and shape my life and experience based on my biggest goals

_A daily sense of deep joy from various activities that require focused attention and skill (work, rock climbing, baking, stretching, meditation)

_Almost every day getting to spend time with the people I love and admire. The people that inspire me and support me.

Looking forward

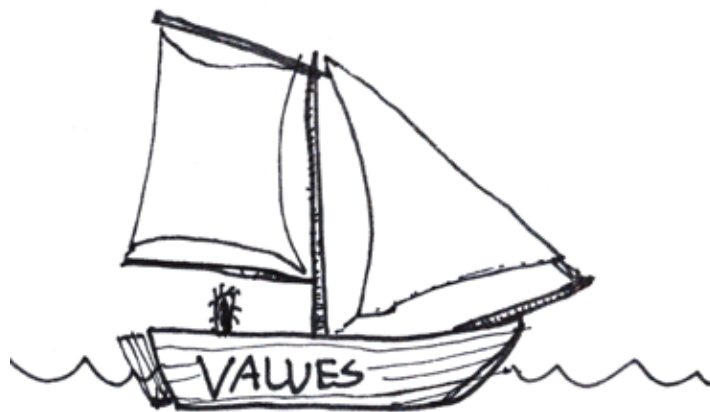

LIFE IS
AS MUCH ABOUT EXPLORING
AS IT IS ABOUT THE DESTINATION.

I'm incredibly excited about 2013. I look forward to continue my work on full speed. With confidence and eagerness to learn and grow. To gain much more experience from doing more work with new and old clients. And at the same time to continue cultivating my own intentionality and my personal growth. Specifically, I still feel that my ability to meditate is quite limited and I have a sense that there is an almost infinite avenue of practice to explore. I'm also excited to continue exploring my own masculine self and build strength in both my body and mind.

One of the most important realizations I have had in 2012 is the importance of being able to hold two contradictory thoughts in my mind at the same time. For example: To

set ambitious goals for the future and focus attention and effort on achieving them while at the same time realizing that my personal happiness does not depend on achieving the goals, but only on the attitude I put into it along the way. Or to be ever grateful for the help and support I receive from others while at the same time also knowing that I support and provide invaluable support for others. It is like saying "thank you and you're welcome". That the ultimate selfish act can be to give to someone else. I think this is what some eastern philosophies refer to as non-duality. That the opposite ends of the same spectrum can in fact meet and become the same thing. It is still a very new idea for me and I look much forward to better understand and internalize it more in 2013.

See
you in
2013

FAREWELL

MY DEAR BELOVED NOTEBOOK

YOU HAVE BEEN PART OF LIFE THROUGH AN
EXCITING AND CHALLENGING PERIOD OF MY
LIFE. YOU HAVE BORN WITNESS TO GREAT
SUCCESS, FLYING HIGH AND TRIUMPH AND
TO FEAR AND DOUBT AND STRUGLES.
AS OUR PATHS PART I AM STILL
FEELING THE GROUND SHAKING BENEATH
MY FEET, AND FEAR AND DOUBT STILL
HIT ME HARD LIKE A BUCKET FULL
OF ICE COLD WATER, WHILE I TRY
MY BEST TO BE PRESENT AND TO
UNHEARTHEADEDLY APPRECIATE MY
POSITION — HAVING CLIENTS + TIME
TO CONTINUE LEARNING. I WANT TO
BE SO MUCH BETTER THAN I AM. I
WANT TO BE BEST, BUT I MUST ALWAYS
ENJOY THE LITTLE STEPS ALONG THE WAY.

SO LOVE. YOUR HUMBLE COMPANION
MATHIAS

Mathias Vestergaard Corp.
1323 Myrtle Ave Apt 3R
Brooklyn NY 11221
USA

T: 347-987-5098

M: m@mathiasvestergaard.com

Twitter: [@ideasarenothing](https://twitter.com/ideasarenothing) & [@mathiasnyc](https://twitter.com/mathiasnyc)

www.ideasarenothing.com

www.mathiasvestergaard.com

MATHIAS
VESTERGAARD™
CORP.